

MAINTENANCE MANUAL INDEX
DOUBLE CHECK AND DOUBLE CHECK DETECTOR
MODELS 850, 856, 870, 870V, 876 AND 876V (2 1/2" - 10")

FEATURES AND OPERATING PROCEDURES

HOW TO ORDER PARTS

TROUBLE SHOOTING PROCEDURES

VANDALISM

TESTING

FREEZE PROTECTION PROCEDURES

GENERAL SERVICE PROCEDURES

SERVICE PROCEDURES FOR MODELS 850, 856, 870, 876, 870V, AND 876V (2-1/2" - 10")

SERVICE PROCEDURES FOR MODEL 805YB 3/4" BYPASS

PARTS/REPAIR KITS FOR MODELS 850, 856, 870, 876, 870V, AND 876V (2-1/2" - 10")

CUT-A-WAY VIEW OF MODEL 850 (2-1/2" - 10")

CUT-A-WAY VIEW OF MODEL 870 AND 870V (STANDARD CONFIGURATION) (2-1/2" - 10")

CUT-A-WAY VIEW OF 10" DISC ASSEMBLY

PARTS/REPAIR KITS AND EXPLODED VIEW OF MODEL 805YB 3/4"

WARRANTY



TABLE OF CONTENTS

Features and Operating Procedures	1
How to Order Parts	1
Trouble Shooting Procedures	2
Vandalism	2
Testing	2
Freeze Protection Procedures	3
General Service Procedures	4
Service Procedures for Models 850, 856, 870, 876, 870V, and 876V (2-1/2" - 10")	5
Service Procedures for Model 805YB 3/4" Bypass	6
Parts/Repair Kits for Models 850, 856, 870, 876, 870V, and 876V (2-1/2" - 10")	7
Cut-a-way View of Model 850 (2-1/2" - 10")	8
Cut-a-way View of Model 870 and 870V (standard configuration) (2-1/2" - 10")	8
Cut-a-way View of 10" Disc Assembly	8
Parts/Repair Kits and Exploded View of Model 805YB 3/4"	9
Warranty	Back Cover

FEATURES AND OPERATING PROCEDURES

Double Check Backflow Preventer Assembly Operation

The FEBCO Double Check Assembly Backflow Preventer consists of two independently operating, spring loaded check valves. The pressure drop across the first check valve is approximately 1.0 PSIG with no flow. The pressure drop across the second check valve is also 1.0 PSIG with no flow.

A complete assembly includes two shut-off valves and four test cocks. NOTE: The 870V and 876V, when installed in the vertical orientation, must include vertical support under the second check body section.

Double Check Detector Bypass Operation

All low flow demands up to a minimum of three GPM are to pass only through the bypass assembly.

All flows above three GPM will pass through both the bypass and mainline valve without accurate meter registration.

HOW TO ORDER PARTS/REPAIR KITS

- 1) Locate item number and kit number in this maintenance manual.
- 2) Verify the size of the valve the parts are to be used on.
- 3) Provide full model number located on I.D. plate.
- 4) Give kit number.
- 5) A serial number (located on the I.D. plate) will assist in ordering the proper kits.
- 6) Contact your local FEBCO Parts Distributor.

TROUBLE SHOOTING PROCEDURES

Symptom No. 1:

Check fails to hold 1.0 PSID minimum.

CAUSES	SOLUTION
A. Debris on sealing surfaces	Inspect and clean
B. Leaking shut-off valve	Inspect and clean, or repair
C. Damaged seat or seat disc	Disassemble and replace
D. Spring stem not moving freely	Inspect for debris or damage

Symptom No. 2:

Chatter during flow conditions.

CAUSES	SOLUTION
A. Worn or damaged parts	Inspect and replace

Symptom No. 3:

Low flows passing through the mainline valve.

CAUSES	SOLUTION
A. Mainline check fouled	Inspect and clean, or repair
B. Bypass plugged (DCDA only)	Inspect and clean

VANDALISM

If the unit is installed where vandalism may be a problem, the assembly should be protected and secured. On 1/2" through 2" units the handles of shut-off valves can be removed to discourage tampering. On 2-1/2" through 10" units, a chain can be looped through both shut-off valve handwheels and locked in position to prevent tampering. Testcock handles can also be removed. On backflow prevention assemblies installed in conjunction with fire sprinkler systems, a tamper switch can be placed on the OS&Y shut-off valves that will trigger an alarm if an unauthorized closure should occur.

A protective enclosure can be installed over the unit to discourage vandals. If an enclosure is used, it should be installed so that adequate clearance is available for maintenance and testing. Consult local codes before installing any type of protective enclosure.

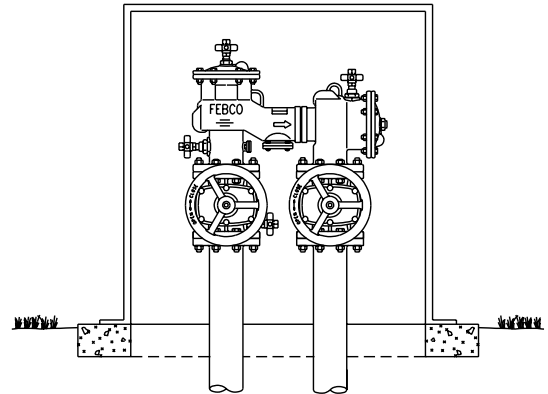

TESTING

All mechanical devices should be inspected on a regular basis to ensure they are working correctly. The assembly should be tested at time of initial installation, after servicing or maintenance, and at least annually thereafter. Acceptable test procedures are published by Foundation for Cross Connection Control and Hydraulic Research at the University of Southern California (USC), The American Water Works Association (AWWA), The American Society of Sanitary Engineering (ASSE Series 5000) and the Canadian Standards Association (CAN/CSA B64•10). Please consult the regulatory authority in your area for more specific information.

FREEZE PROTECTION

The Double Check Backflow Prevention Assembly may be subject to damage if the internal water is allowed to freeze. The unit must be protected from freezing using a heated enclosure, insulation using heat tape, or other suitable means. The unit must always be accessible for testing and maintenance. If the system will be shut down during freezing weather, use the following procedures to drain internal passages.

Ball Valve Shut-Off Draining Procedure

If the assembly has been installed with ball valve shut-off valves, they must also be properly drained to prevent freeze damage. After draining procedure has been completed on the backflow prevention assembly, position all ball valve shut-offs and test cocks in a half open/half closed (45 degree) position.

Open the ball valve approximately 45 degrees while draining the pipeline and assembly to allow water between the ball valve and valve body to drain. Leave the ball valve in this position for the winter to prevent freeze damage.

The ball valve must be fully closed before the system is repressurized. **OPEN AND CLOSE BALL VALVES SLOWLY TO PREVENT DAMAGE TO THE SYSTEM CAUSED BY WATER HAMMER.**

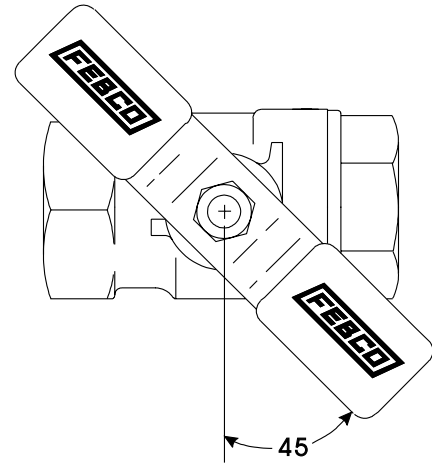

Main Valve Draining Procedure (1/2" - 2")

1. Close the main shut-off valve.
2. Open the inlet drain.
3. Open the inlet and outlet ball valves 45 degree (half open, half closed).
4. Open all testcocks.
5. Open the outlet drain.
6. Remove the cover and inlet check module until all water inside valve drains back out through inlet drain.
7. If you "blowout" the piping downstream of the backflow assembly using compressed air:

Connect the air supply to the outlet drain and close the outlet ball valve. After clearing the system with air, partially open the outlet ball valve. Leave all drain valves, testcocks, and ball valves in half open/half closed position for the winter (see above for more detailed instructions).

Main Valve Draining Procedure (2-1/2" - 10")

Slowly close supply valve within freeze protected area, open all test valves on the backflow preventer. For sizes 2-1/2" - 10", water within the zone between the two checks may be drained by loosening the bolts (item 24) on the bottom cover plate (item 19) (see page 8).

All water will be drained from the inlet side and the zone between the two checks of the Model 870. All water on the inlet side will be drained down to the No. 1 test cock on the Model 850. The remaining water on the inlet side may be drained to the lowest point on the Model 850 (2-1/2" - 10") by removing the small (item 36) bottom plate (see page 8). If you desire to add a drain plug there is sufficient material for drilling and tapping 1/4" IPS thread in the cover (item 19), however, adding a drain plug is not necessary. Loosen the mounting nuts and bolt to allow drainage from beneath the plate.

The system design must provide a means for draining upstream of the #1 shut-off valve and downstream of the #2 shut-off valve.

Position the assembly shut-off valves and test cocks in the half open/half closed position to allow complete draining of the assembly shut-off valve bodies and test cocks (see above).

GENERAL SERVICE PROCEDURES (1/2" - 10")

1. FEBCO backflow prevention assemblies can be serviced with standard tools and are designed for ease of maintenance. The assemblies are designed to be serviced in line, so the unit should not need to be removed from the line during servicing. NO special tools are required.
2. The most common cause of check fouling is dirt and debris in the seating areas. The line should be flushed clean of debris before installation of the assembly. To flush the line after installation of the assembly, slowly close the inlet shut-off valve, remove the covers and spring assemblies of both check valves and open the inlet shut-off valve to allow sufficient flow of water through the assembly to clear all sand, debris, etc. from the line. If debris in the water continues to cause fouling, a strainer may be installed upstream of the assembly (check local codes).
3. Rinse all parts with clean water before reassembly.
4. Lubricant is recommended only for #2 check cover o-ring to help hold o-ring in place during reassembly (models 870, 876, 870V, and 876V). Use petroleum jelly (food grade).
5. Carefully inspect seals and seating surfaces for damage or debris. If the check valve seat disc has been severely cut at the seat ring diameter, the assembly has been subjected to extremely high and repeated back pressure. Either thermal water expansion or water hammer are the most likely causes. If back pressure persists, consider installation of a pressure relief valve downstream of the assembly.
6. Use caution to avoid damaging any guiding surfaces while handling parts. Do not force parts together. The o-ring seals used in FEBCO assemblies require only a small tightening force to insure a positive seal.
7. Test unit after servicing in accordance with locally approved test methods to insure proper operation (see page 2 for more details).
8. Refer to applicable parts lists and cut-a-ways (pages 7-9) for visual aid information.
9. Use petroleum jelly (food grade).

SERVICE PROCEDURES FOR MODELS 850, 856, 870, 876, 870V, 876V (2-1/2" - 10")

Check Valve Disassembly and Resassembly

1. Spring Module Removal

- a. Slowly close outlet shut-off valve and inlet shut-off valve. Bleed residual pressure by opening #4, #3, and #2 test cocks (see page 8 for test cock location).
- b. Remove cover bolts, removing the two bolts last that are located next to the retainer pin. Remove cover.
NOTE: Spring module is positioned in the body by the cover. Spring module is captured.
- c. Refer to page 7-8. Remove pivot bearing (item 13) from the upper spring retainer of the spring module. Inspect pivot bearing (item 13) and bearing socket (item 15). Small hole in bearing socket indicates replacement is required. Remove retaining clip (item 5.1) from groove on one end of the load pin (item 7). Hold spring module with one hand while sliding out load pin (item 7) from arm (item 4). Lift out spring module and inspect for wear or damage. Replace spring module if necessary.

2. Check Disk Removal

- a. Remove jam nut (item 16) and washer (item 17) from check disc stem threads. Lift the arm and remove the check disc (item 6). Inspect sealing surface for debris or damage. Replace check disc if necessary.
NOTE: When jam nut (item 16) is tight, check disc is designed to "wobble."

3. Seat Ring Assembly Removal

NOTE: Remove the seat ring assembly only if the seat ring (item 3) or arm (item 4) appear to be worn or damaged.

- a. Remove locknuts (item 3.4) (see drawing on right).

NOTE: When reassembling, tighten locknuts to 12-15 ft./lbs. If leaking occurs around bolt, further tighten until leaking stops. Do not over tighten.

- b. Remove seat ring assembly.
- c. Remove retaining clip (item 5) from one end of the swing pin (item 4.2). Hold arm (item 4) while sliding out swing pin (item 4.2). Inspect bushings (item 4.1) and pin (item 4.2) for wear or damage. Replace if necessary. Inspect gasket (item 3.1) for debris and/or damage. Replace if necessary.

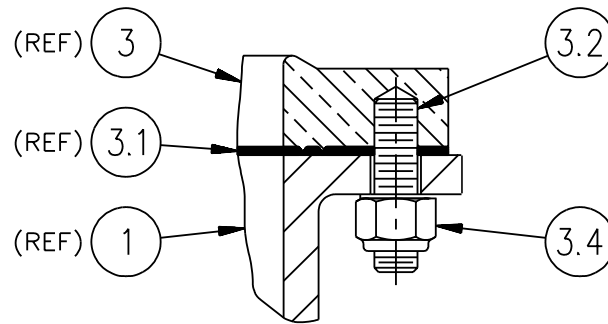

NOTE: Reverse the previous procedure to reassemble the components. Seat ring will only fit into body one way. Check alignment of seat ring if studs do not align with body holes. Gasket is also non-symmetric. Both seat ring and gasket have a notch that indicates non-symmetric hole. Clean all parts thoroughly with clean water before reassembly. Reassemble and bleed test cocks #4, and #3. Repressurize the assembly and test to ensure proper operation.

SERVICE PROCEDURES FOR MODEL 805YB — 3/4" BYPASS

1. Bypass Check Valve Inspection/Repair Model 805YB 3/4" (see page 9).
 - a. Close inlet and outlet shut-off valves. Bleed residual pressure by opening first the #4 test cock, then the #3 and #2 test cocks.
 - b. Unscrew Cap using appropriate size wrench. NOTE: Cap is spring loaded.
 - c. Remove the spring and disc holder assembly.
 - d. Inspect guiding bore of the cap and poppet stem for any buildup of calcium or other mineral deposits. If this condition exists, it may be removed with the careful use of a 5/8" (.6250) reamer or a thin blade knife.
 - e. Check disc holder and stem movement in the guide to insure they move freely. Debris can inhibit proper movement.
2. Check Valve Seat Disc Replacement Model 805YB (3/4") (see page 9).
 - a. Hold disc holder assembly in one hand and remove screw and disc washer.

CAUTION: The use of pliers or other tools may damage the guiding surfaces and require unnecessary replacement. Do not scratch or mark sealing or guiding surfaces.
 - b. Inspect seat disc for wear or cuts. Remove old seat disc and replace. Disc may be turned over for **temporary** repair until a new disc is available.
 - c. If the seat disc has been severely cut along the seat ring diameter, the assembly is being subjected to extremely high back pressure from thermal water expansion, water hammer or other causes of excessive water pressure. Seat discs damaged in such a manner should be replaced and not turned over to be reused.
3. Check Valve Reassembly Model 805YB (3/4") (see page 9).
 - a. Position the disc in the cleaned holder and retain with disc washer and screw.
 - b. Position the spring around the centering ring of the disc holder and reinsert the disc holder assembly into the check body.
 - c. Apply a thin coating of petroleum jelly (food grade) on the o-ring in the cap and thread cap onto the check valve body using the appropriate sized wrench.
 - d. Close the #4, #3, and #2 test cocks and slowly open first the inlet and then outlet shut-off valves and return the assembly to service.
 - e. Test the assembly to insure it is operating properly.

MODEL 856 BYPASS

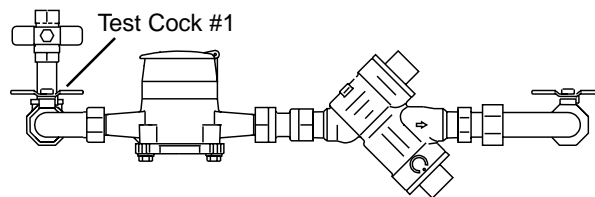

MODEL 876/ 876V BYPASS

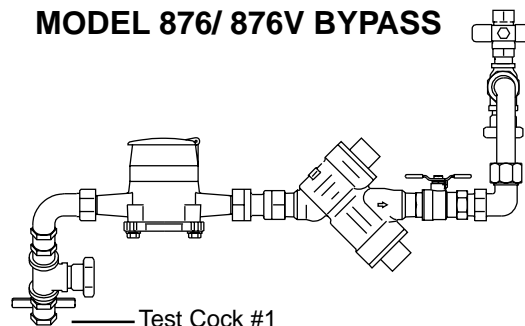

MODEL 850 / 856 / 870 / 870V / 876 / 876V (2-1/2" - 10") — PARTS/REPAIR KITS LIST

ITEM	DESCRIPTION	MATERIALS	ITEM	DESCRIPTION	MATERIALS	ITEM	DESCRIPTION	MATERIALS
1	Body	A536 GR 65-45-12	6.2	Disk Retainer (10")	ASTM A743 304SS	19	Cover	A36 Steel Exproy Ct.
2	Cover (w/hole)	A536 GR 65-45-12	6.3	Capscrew (10")	Stainless Steel	24	Bolt	Plated Steel
2.1	O-Ring	EPDM ASTM D2000	7	Load Pin	Stainless Steel	25	Bolt	Plated Steel
2.2	Cap Screw	Plated Steel	8	Lwr Spring Retnr	B584 Alloy C83600	26	Gasket	EPDM ASTM D2000
2.3	Hex Nut	Plated Steel	9	Spring Stem	Stainless Steel	35	O-Ring	EPDM ASTM D2000
2.5	Cover (w/o hole)	A536 GR 65-45-12	9.1	Elastic Stop Jam Nut	Stainless Steel	35.1	Back-Up Ring	Acetal Resin
3	Seat Ring	B584 Alloy C83600	10	Spring	A313 Type 631 SS	36	Cover	B584 Alloy C83600
3.1	Gasket	EPDM ASTM D2000	10.2	Spring Shim	Acetal Resin	40	Ball Valve	B584 Alloy C84400
3.2	Socket Head Screw	18-8 SS	10.3	Spring Shim	Acetal Resin	41	Nipple	Brass
3.4	Washer	304 SS	11	Spring Guide	B130 Alloy C22000	42	Gate Valve (NRS)	AWWA C509
4	Arm	B584 Alloy C83600	12	Upr Spring Retnr	B584 Alloy C83600	43	Bulkhead Fitting	B584 Alloy C83600
4.1	Bushing-Swing Pin	Acetal Resin	12.1	Bushing-Spr. Stem	Acetal Resin	43.1	Bulkhead Fitting	B584 Alloy C83600
4.2	Swing Pin	Stainless Steel	13	Pivot Bearing	B585 Alloy C83600	44	Bulkhead Plug	Brass
5	Retaining Clip	Stainless Steel	14	Flange Gasket	Rubber/Fabric	45	Gasket	EPDM ASTM D2000
5.1	Retaining Clip	Stainless Steel	15	Bearing Socket	Acetal Resin	45.1	Gasket	EPDM ASTM D2000
6	Check Disk (2-1/2"-8")	EPDM Coated GR, 45 Ductile Iron with type 304 SS stem	16	Hex Jam Nut (2-1/2"-8")	18-8 SS	46	Washer	B36 Alloy 260
	Seat Disk (10")	Silicone ASTM D2000		Capscrew (10")	18-8 SS	46.1	Washer	B36 Alloy 260
6.1	Disk Holder (10")	ASTM A743 304SS	17	Washer	302 SS	47	Nut	B584 Alloy C83600
			18	Flange Nut	Plated Steel	47.1	Nut	B584 Alloy C83600
			18.1	Flange Nut	Plated Steel	70	Clamp (870V/876V only)	AWWA C606 (850/856 10" only)

Note: Bulkhead fittings are not furnished on the Model 850 or 856.

KIT DESCRIPTION	2-1/2"	3"	4"	6"	8"	10"	
Check Replacement Kit (items 2.1, 3, 3.1, 3.2, 3.4, 4, 4.1, 4.2, 5, 5.1, 6, 7, 8, 9, 9.1, 10, 11, 12, 12.1, 13, 15, 16, 17)	850 870(V) 856 876(V)	905-527 905-528 905-529 905-530	905-527 905-528 905-529 905-530	905-534 905-534 905-536 905-536	905-537 905-537 905-538 905-538	905-539 905-539 905-541 905-541	905-539 905-540 905-541 905-542
850/870 DC Inlet Spring Module (items 5.1, 7, 8, 9, 9.1, 10, 11, 12, 12.1) (8" - item 10.2)		905-142	905-142	905-143	905-144	905-145	905-145 (850) 905-146 (870)
856/876 DCDA Inlet Spring Module (items 5.1, 7, 8, 9, 9.1, 10, 10.2, 11, 12, 12.1) (8" - item 10.3)		905-147	905-147	905-148	905-149	905-150	905-150 (856) 905-151 (876)
850/870 DC Outlet Spring Module (items 5.1, 7, 8, 9, 9.1, 10, 11, 12, 12.1) (8" - item 10.2)		905-142	905-142	905-143	905-144	905-145	905-145 (850) 905-146 (870)
856/876 DCDA Outlet Spring Module (items 5.1, 7, 8, 9, 9.1, 10, 10.2, 10.3, 11, 12, 12.1) (8" - item 10.3)		905-147	905-147	905-148	905-149	905-150	905-150 (856) 905-151 (876)
850/856 Disc Assembly (items 6, 16, 17) (10" - item 6 only)		905-182	905-182	905-153	905-154	905-155	905-155
870/876 Disc Assembly (items 6, 16, 17)		905-152	905-152	905-153	905-154	905-155	400-145
Seat Ring / Arm Assembly (items 3, 3.1, 3.2, 3.4, 4, 4.1, 4.2, 5)		905-157	905-157	905-158	905-159	905-160	905-160 (850/856) 905-161 (870/876)
850/856 Rubber Kit (items 2.1, 3.1, 6, 15, 26, 35, 35.1, 45, 45.1)		905-249	905-249	905-163	905-164	905-165	905-165
870/876 Rubber Kit (items 2.1, 3.1, 6, 15, 26, 35, 35.1, 45, 45.1)		905-162	905-162	905-163	905-164	905-165	905-166
850/856 Cover Assembly both checks 876(V) Inlet Check only (items 2, 2.1, 15)		905-167	905-167	905-168	905-169	905-170	905-170 (850/856) 905-171 (876V)
870(V)/876(V) Cover Assembly Outlet Check only (items 2.1, 2.5, 15)		905-244	905-244	905-245	905-246	905-247	905-248
Bulkhead Fittings Assembly Cover (items 43.1, 45.1, 46.1, 47.1)		905-275	905-275	905-275	-	-	-
Bulkhead Fittings Assembly Cover (items 43, 45, 46, 47)		905-276	905-276	905-276	-	-	-
Bulkhead Fittings Assembly Body & Cover (items 43, 45, 46, 47)		905-277*	905-277*	905-277*	905-277	905-277	905-277
Bulkhead Plug Assembly 2nd Check Cover (N & V Units) Early Prod. (items 44, 45.1, 46.1, 47.1)		905-278	905-278	905-278	-	-	-
Bulkhead Plug Assembly 2nd Check Cover (N & V Units) Early Prod. (items 44, 45, 46, 47)		-	-	-	905-279	905-279	905-279

* Models 856 and 876 only. Some of the above items are only available as part of a repair kit.

MODEL 850/856 (2-1/2" - 10")

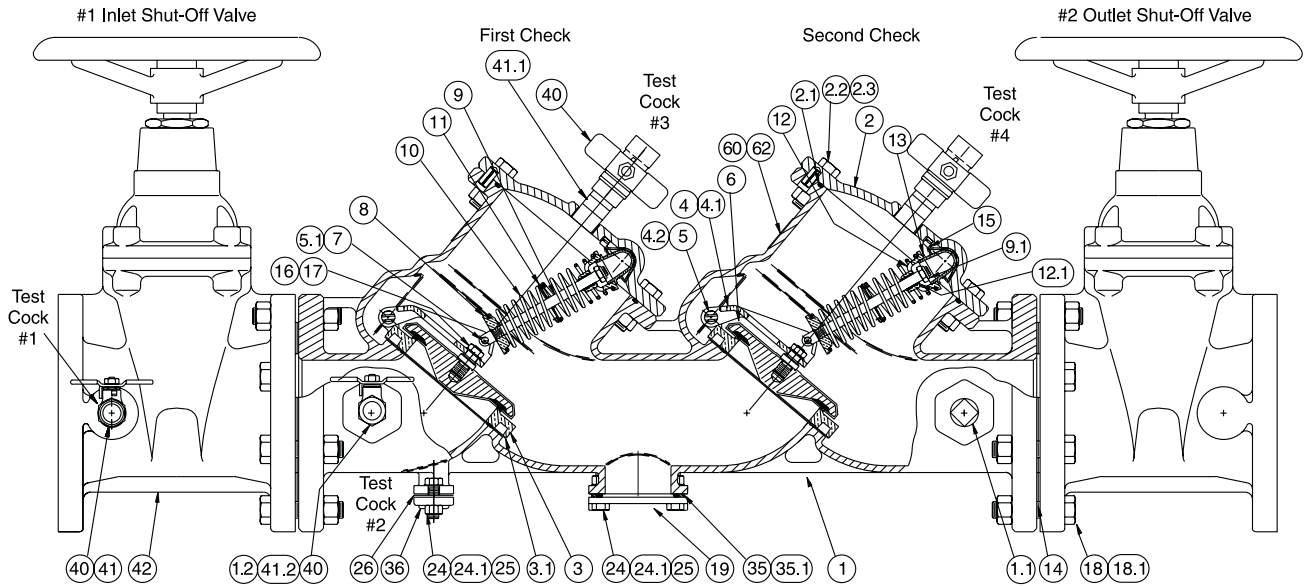

Notes: Bulkhead fittings are not furnished on the Model 850 or 856.
850 and 856 10" include Item 70 (clamp) not shown.

MODEL 870 / 870V / 876 / 876V (2-1/2" - 10")

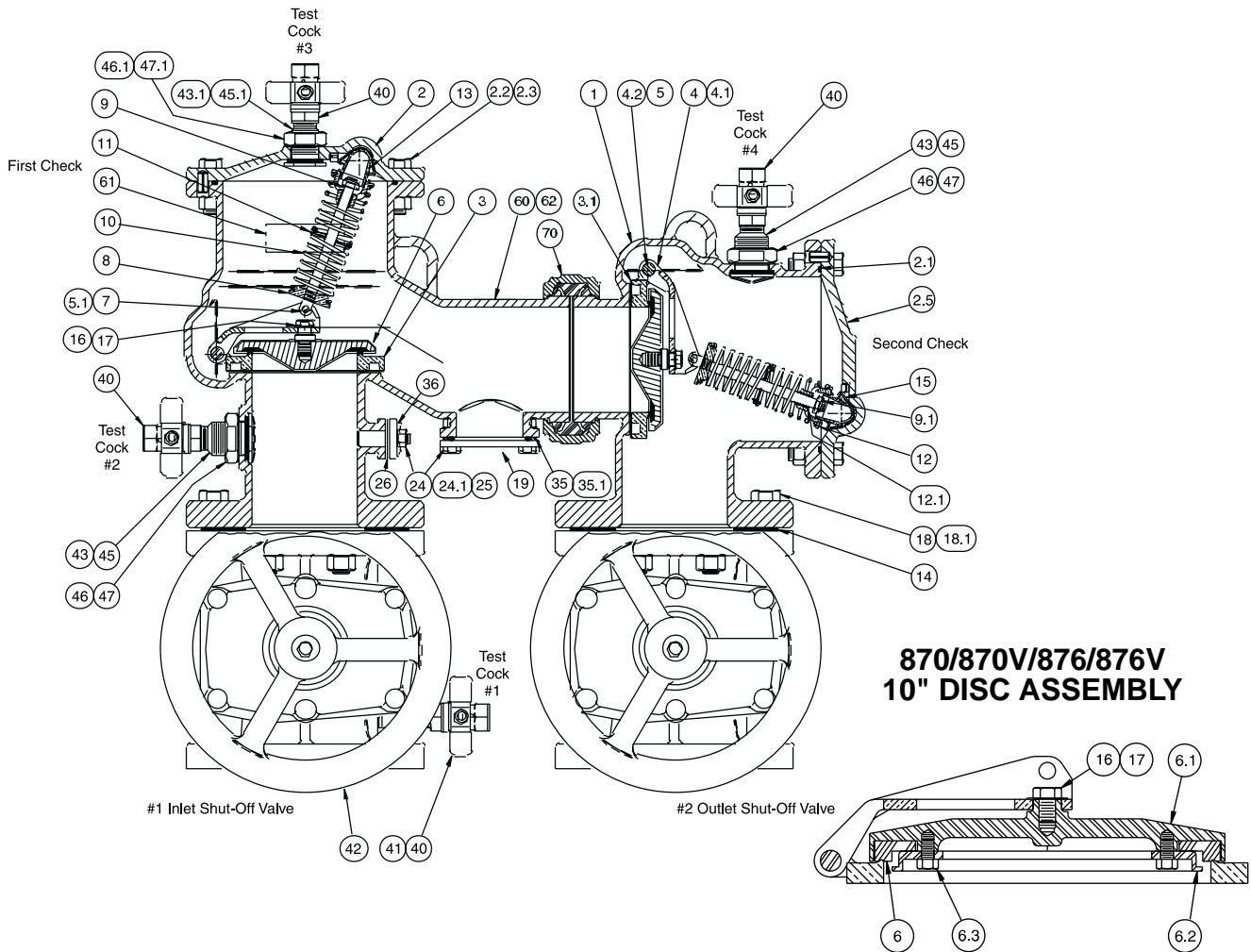

MODEL 805YB 3/4" BYPASS DOUBLE CHECK — PARTS/REPAIR KITS LIST

ITEM	DESCRIPTION	MATERIALS	ITEM	DESCRIPTION	MATERIALS	ITEM	DESCRIPTION	MATERIALS
1	Body	Bronze	36	O-ring	Buna-n	309	Elbow	Bronze
7	Cap	Bronze	40	Ball Valve	Bronze	311	Elbow	Bronze
8	O-Ring	Buna-n	40.1	Ball Valve	Bronze	312	Fitting	Bronze
9	Disc Holder	Acetal	40.2	Ball Valve w/tap	Bronze	314	Fitting	Bronze
10	Seat Disc	Nitrile	40.3	Test Cock	Bronze	315	Tee	Brass
11	Washer	Stainless Steel	300	Water Meter		316	Elbow	Copper
12	Screw	Stainless Steel	301	Nipple	Brass	317	805YB-3/4"	
13	Spring	Stainless Steel	302	Nipple	Brass	P/N 905-042	805YB Rubber Repair Kit	
30	Test Cock	Bronze	303	Nipple	Brass	P/N 905-044	805 YB Check Assembly	
35	Seat Ring	Bronze	305	Nipple	Brass			

MODEL 876/876V BYPASS

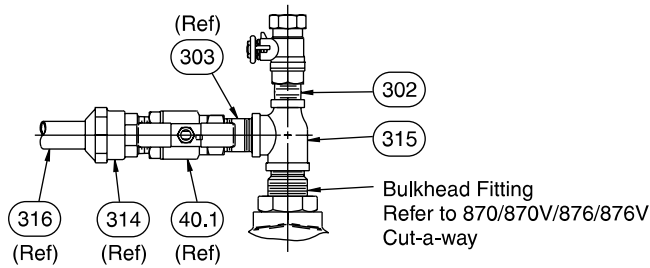
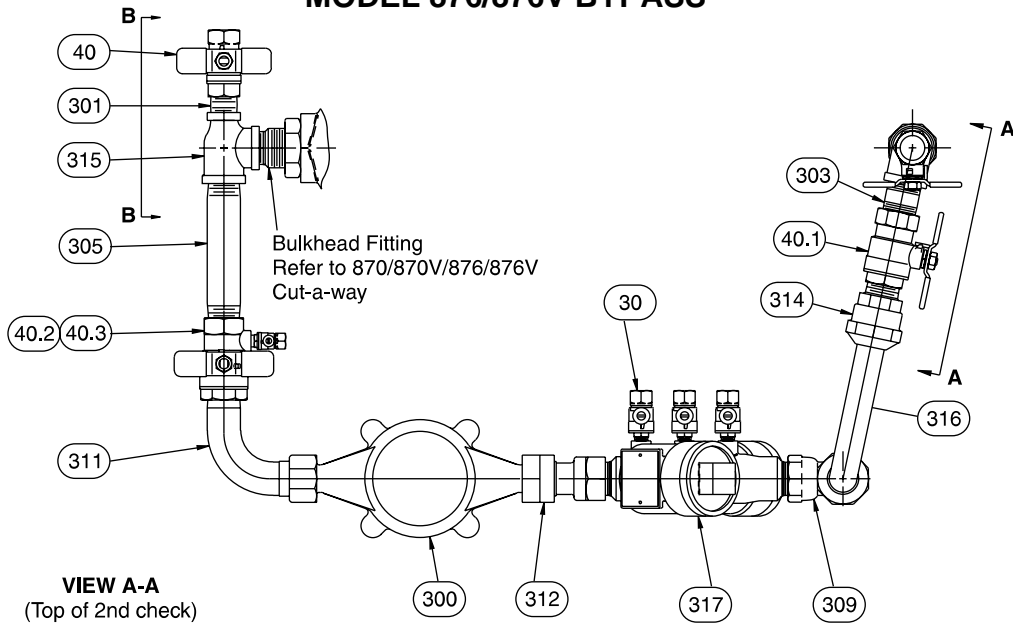

VIEW B-B
(Inlet side of valve)

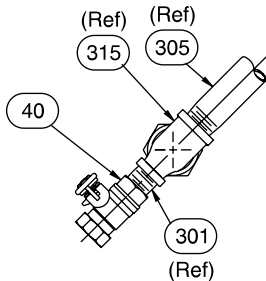

MODEL 805YB 3/4" BYPASS DOUBLE CHECK ASSEMBLY

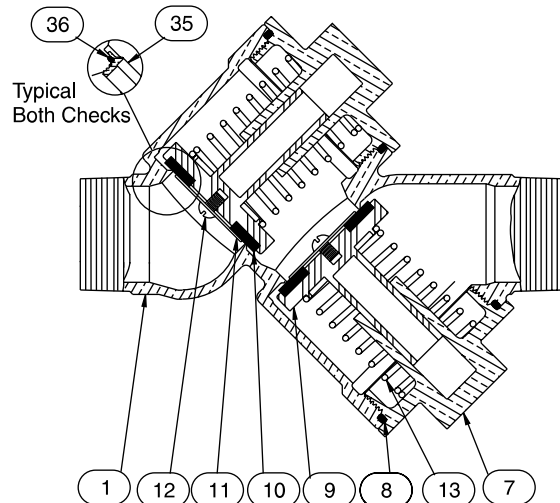

FEBCO PERFORMANCE, VALUE, AND QUALITY

FEBCO MasterSeries® (2½" - 10")

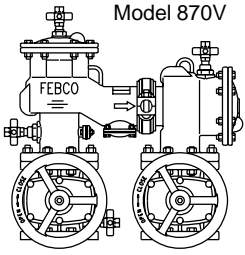
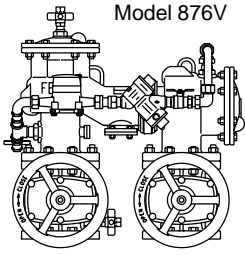
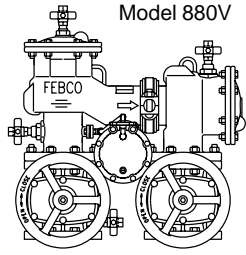
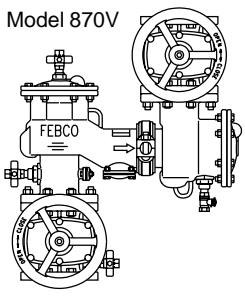
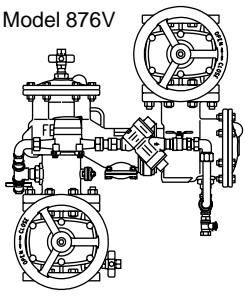
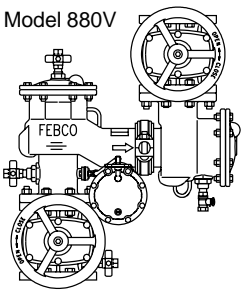
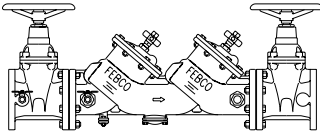
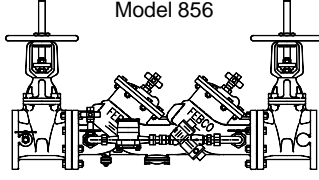
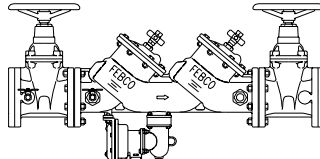
	Double Check Assembly	Double Check Detector Assembly	Reduced Pressure Assembly
"N" - Shape	 <p>Model 870V</p>	 <p>Model 876V</p>	 <p>Model 880V</p>
Vertical	 <p>Model 870V</p>	 <p>Model 876V</p>	 <p>Model 880V</p>
Conventional In-Line	 <p>Model 850</p>	 <p>Model 856</p>	 <p>Model 860</p>

For nearly half a century customers have looked to FEBCO for quality products, reliable low headloss performance, and great value. Today, with the new FEBCO MasterSeries® designs, FEBCO has once again taken the initiative with patented product innovations.

All 2½ through 10" MasterSeries products include:

- Patented VectorCheck performance for low head loss
- Cast ductile iron bodies for lighter weight
- Lowest installed cost — Saves on labor and material
- Choice of cost-saving "N"-Shape designs, revolutionary vertical designs, or conventional in-line designs.

Contact a FEBCO representative today for product literature and technical specifications on FEBCO MasterSeries® backflow prevention products.

WARRANTY

All products manufactured and sold by CMB Industries, Inc. carry with them the following warranty: CMB Industries, Inc. warrants to the original purchaser (who is the end user) all products manufactured by it will be free from defects in workmanship and material for a period of one (1) year from the date of original shipment.

CMB Industries, Inc. also warrants that all internal components of 1/2" through 2" Model 850/860 and 1/2" through 1" Model 766 products, will be free from defects in workmanship and material for a period of five (5) years from the date of original shipment and also that the body only of the 1/2" through 1 1/4" Model 765 will be subject to a lifetime warranty against damage by freezing.

This warranty is applicable provided such products are used under normal conditions within the recognized pressure, flow and temperature limits and are given normal service and care. CMB INDUSTRIES, INC. MAKES NO OTHER REPRESENTATION OR WARRANTY OF ANY KIND, EXPRESSED OR IMPLIED, IN FACT OR IN LAW, AND EXPRESSLY DISCLAIMS ALL OTHER WARRANTIES, INCLUDING WITHOUT LIMITATION, THE WARRANTIES OF MERCHANTABILITY OR FITNESS FOR PARTICULAR PURPOSE. In the event of a defect in material or workmanship of a product covered by this warranty, CMB Industries, Inc. shall, at its sole option, repair or replace such defective product. CMB Industries, Inc. shall not be liable for any labor required to repair or replace any product covered by this warranty. This warranty is void with respect to any such product which is altered or tampered with by anyone without prior consent of CMB Industries, Inc. CMB Industries, Inc. shall not be liable under any circumstances for damages caused by accident, misuse or abuse of the product or for failure to follow the installation, maintenance or operating instructions. IN NO EVENT SHALL CMB INDUSTRIES BE LIABLE FOR CONSEQUENTIAL, INCIDENTAL, INDIRECT, PERSONAL INJURY, PROPERTY OR PUNITIVE DAMAGES.

To make a claim under this warranty, the buyer must notify the factory in writing within ten (10) days of discovery of any claimed defects or workmanship, and if authorized by the factory, shall return the product in the same condition as when received by the buyer, transportation prepaid, to the factory or to such other location as directed by the factory. If said returned product is found by the factory to be defective in workmanship or materials, it shall be repaired or replaced without charge, pursuant to the terms of this warranty. This warranty excludes component parts or appurtenances not manufactured by CMB Industries, Inc. Any claims with respect to such equipment must be made to the manufacturer thereof in accordance with the terms of the warranty, if any, given by such manufacturer, or pursuant to such warranties as may exist by law. The physical or chemical properties of CMB Industries, Inc. products represent typical, average values obtained in accordance with test methods and are subject to normal manufacturing variations. This information is supplied as a technical service and is subject to change without notice.

FEBCO BACKFLOW PREVENTION...

A product of CMB Industries, Inc.

CMB Industries Inc. is a leader in the water control market with more than 75 years of experience in the design and manufacturing of the world's most innovative water control products. CMB products include FEBCO Backflow Preventers, K-FLO Butterfly Valves and POLYJET Control Valves. As an ISO 9001 Certified manufacturer, CMB is committed to quality and performance.

For more information about FEBCO Backflow Preventers, visit our web site at www.FEBCOonline.com or request our interactive CD, CMB+, with its electronic catalog, valve selection guide, and technical drawings and data.



CMB Industries, Inc.

ISO 9001 Certified

Post Office Box 8070 • Fresno, California • U.S.A.

Tel# (559) 252-0791 • Fax# (559) 453-9030 • www.cmb-ind.com • www.FEBCOonline.com

Copyright 2001 CMB Industries, Inc.

MMDCDCD 6/01
PN 980115