

Series 757a/757aDCDA

RP/IS-757a/757aDCDA

Double Check Valve Assemblies Double Check Detector Assemblies

Sizes: 2½" – 6" (65 – 150mm)

- Installation
- Service
- Repair Kits
- Maintenance

For field testing procedure, send for IS-TK-DL, IS-TK-9A, IS-TK-99E and IS-TK-99D.

For other repair kits and service parts, send for PL-RP-BPD and F-RK-DC.

For technical assistance, contact your local Watts representative.

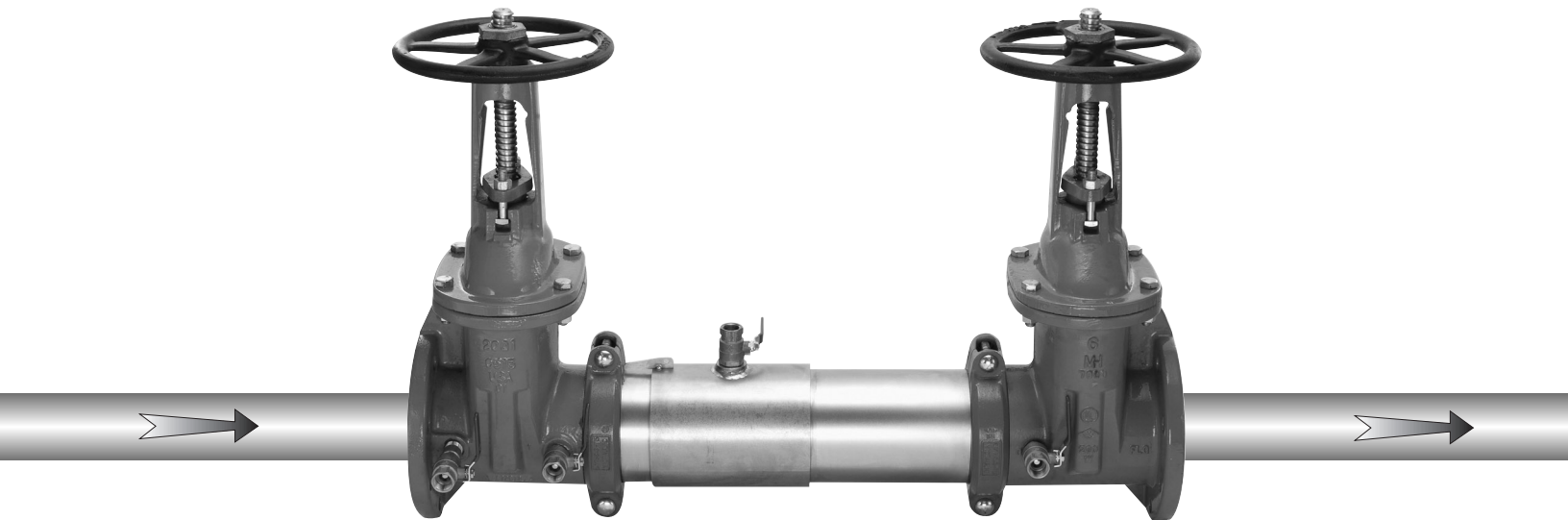

Watts 757a OSY

CALIFORNIA PROPOSITION 65 WARNING

WARNING: This product contains chemicals known to the State of California to cause cancer and birth defects or other reproductive harm. (Installer: California law requires that this warning be given to the consumer.)

For more information: www.wattsind.com/prop65

IMPORTANT: Inquire with governing authorities for local installation requirements.

NOTE: For Australia and New Zealand: Pipeline strainers should be installed between the upstream shutoff valve and the inlet of the backflow preventer.

Its important that this assembly be tested periodically in compliance with local codes, but at least once per year or more as service conditions warrant. If installed on a fire sprinkler system, all mechanical checks, such as alarm checks and backflow preventers, should be flow tested and inspected internally in accordance with NFPA 13 and NFPA 25.

Limited Warranty: Watts Regulator Company warrants each product to be free from defects in material and workmanship under normal usage for a period of one year from the date of original shipment. In the event of such defects within the warranty period, the Company will, at its option, replace or recondition the product without charge. This shall constitute the sole and exclusive remedy for breach of warranty, and the Company shall not be responsible for any incidental, special or consequential damages, including without limitation, lost profits or the cost of repairing or replacing other property which is damaged if this product does not work properly, other costs resulting from labor charges, delays, vandalism, negligence, fouling caused by foreign material, damage from adverse water conditions, chemical, or any other circumstances over which the Company has no control. This warranty shall be invalidated by any abuse, misuse, misapplication or improper installation of the product. **THIS WARRANTY IS IN LIEU OF ALL OTHER WARRANTIES, EXPRESS OR IMPLIED, INCLUDING ANY IMPLIED WARRANTIES OF MERCHANTABILITY OR FITNESS FOR A PARTICULAR PURPOSE.** Any implied warranties that are imposed by law are limited in duration to one year.

Some States do not allow limitations on how long an implied warranty lasts, and some States do not allow the exclusion or limitation of incidental or consequential damages. Therefore the above limitations may not apply to you. This Limited Warranty gives you specific legal rights, and you may have other rights that vary from State to State. You should consult applicable state laws to determine your rights.

WATTS[®]
REGULATOR

Basic Installation Instructions

Guidelines

Most field problems occur because dirt and debris present in the system at the time of installation becomes trapped in the #1 check. The system should be flushed before the backflow valve is installed. If the system is not flushed until after the backflow valve is installed, remove both check modules from the valve and open the inlet shutoff to allow water to flow for a sufficient time to flush debris from the water line. If debris in the water system continues to cause fouling, a strainer can be installed upstream of the backflow assembly.

Watts models 757a and 757aDCDA may be installed in either horizontal or vertical position as long as the backflow assembly is installed in accordance with the direction of the flow arrow on the assembly and the local water authority approves the installation. The assembly should be installed with adequate clearance around the valve to allow for inspection, testing and servicing. 12" should be the minimum clearance between the lower portion of the assembly and the floor or grade.

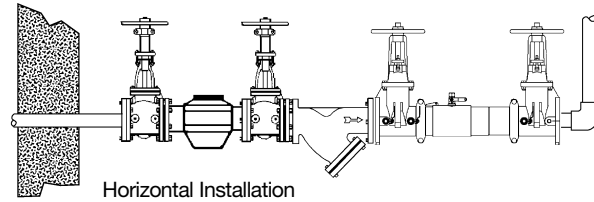

Horizontal Installation

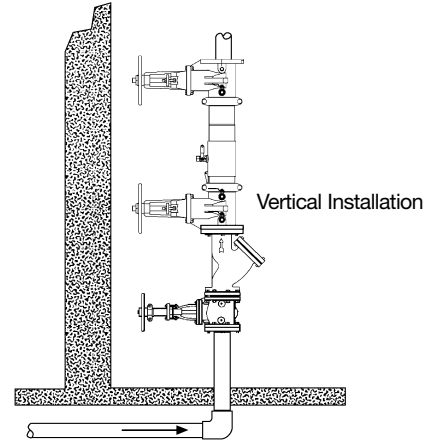

Vertical Installation

Maintenance Instructions

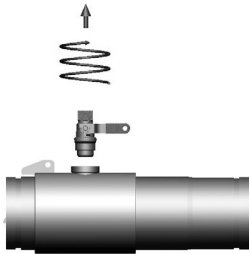

Figure A

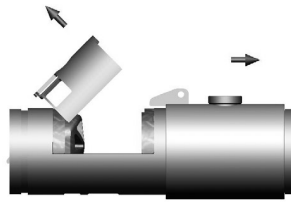

Figure B



Figure C

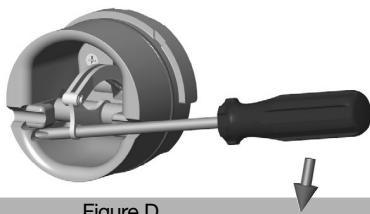

Figure D

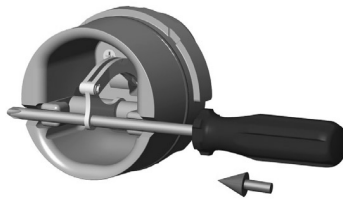

Figure E



Figure F

Prior to servicing any Watts valve, it is mandatory to shut down the water system by closing both the inlet and outlet shutoff valves. After shutoff valves are closed, open test cock #2, #3 and #4 to relieve pressure within the backflow assembly.

1. After #3 test cock has been opened to relieve pressure, remove #3 test cock from housing. (Figure A)
2. Slowly slide the cover sleeve to the downstream side of the housing. (Figure B)
3. Remove the stainless steel check retainer from the housing. (Figure B)
4. Remove the #1 check module (Figure C) by inserting two flat blade screwdrivers into the slots on either side of the check module and gently pry to check module toward the open zone.
5. Remove #2 check module with the same instructions as in #4 above.

6. To clean or inspect either check module, insert a #3 screwdriver through the downstream side of the check module as shown in Figure D and E. When the screwdriver is in place, remove the E-clip (Figure F) and pin connecting the structural members and the check clapper will open with no tension.
7. Thoroughly clean the seating area. The sealing disk may be removed, if necessary, by removing the screws connecting the keeper plate to the clapper. The sealing disc may be reversed and reinstalled if the elastomer is cut or damaged.
8. Wash check module and O-ring and inspect for any damage. If damaged, reinstall new parts.
9. After thorough cleaning, lubricate O-ring w/FDA approved lubricant, replace pin and E-clip in structural members, remove screw driver and reinstall check modules and assemble housing in reverse order of these instructions.

Test Procedures

Double Check Valve Assemblies

Test Check Valve No.1

- Step 1: Ensure shutoff #1 is open, shutoff #2 is closed.
- Step 2: Connect high side hose to test cock #3, low side to test cock #2 and open both test cock #2 and test cock #3.
- Step 3: Open valve C, then open A to bleed air from the high side. close valve a, then open B to bleed low side. Close valve B.
- Step 4: Connect vent hose loosely to test cock#1. Open valve A to vent air from vent hose, Tighten vent hose at test cock #1, open test cock #1.
- Step 5: Close shutoff #1. Slowly loosen hose at test cock #2 until differential gauge rises to 2psi and retighten hose. If the differential reading does not decrease, record check valves as "tight".

Test Check Valve No. 2

- Step 1: Move the high side hose to test cock #4, low side to test cock #3 and open both test cock #3 and test cock #4. Remove vent hose from test cock #1, open shutoff #1.
- Step 2: Open valve C, then open valve A to bleed air from the high side. Close valve A, then open valve B to bleed low side. Close valve B.
- Step 3: Connect vent hose loosely to test cock #1. Open valve A to vent air from the vent hose, Tighten vent hose at test cock #1, open test cock #1.
- Step 4: Close shutoff #1, then slowly loosen hose at test cock #3 until differential gauge rises to 2psi and retighten hose. If the differential reading does not decrease, record check as tight. Remove all hoses and restore valve to original working condition.

Note: The assembly will fail both the first and second check valve tests above, if shutoff #2 leaks excessively. To test for a leaky #2 shutoff, use the following procedure.

Test for Leaky No. 2 shutoff

- Step 1: Connect the high side to test cock #1, low side to test cock #4. Open test cock #1 and test cock #4. Close shutoffs #1 and #2.
- Step 2: Close valve C. Open valve A, then open valve B 1/2 turn, loosen hose at test cock #4 to remove air. Retighten hose.
- Step 3: If the differential gauge rises above 0, there is excessive leakage at shutoff #2 and it must be replaced to test the assembly.

Ball Type Test Valves

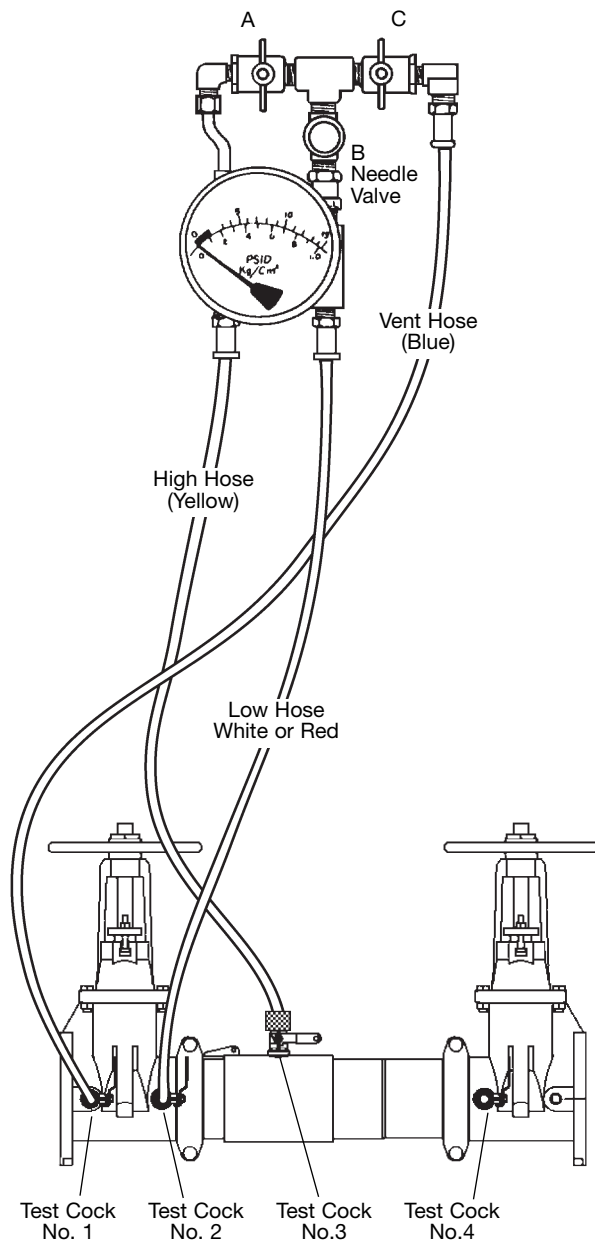

757a/757aDCDA Repair Kits

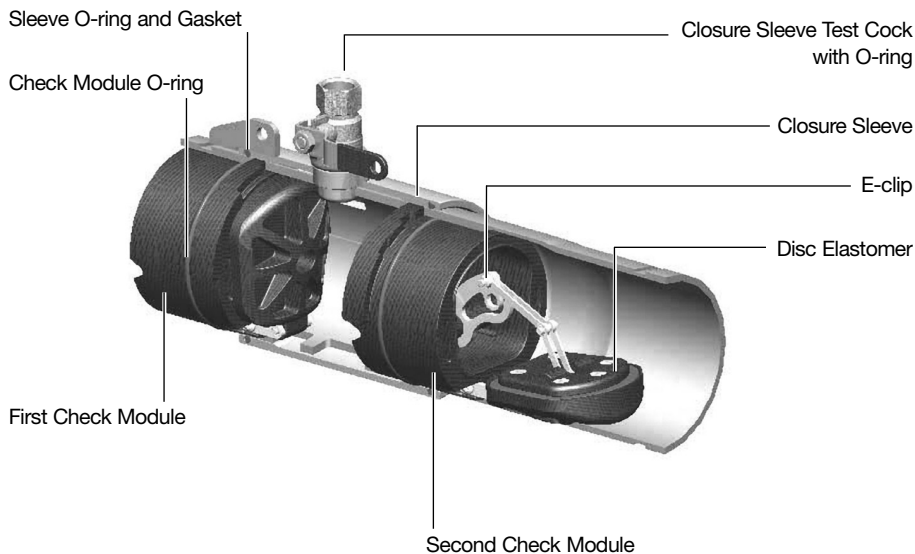

ORDERING NO.	SIZE	MODEL
--------------	------	-------

1st Check Kits

0899250	2½" - 4"	RK 757a/757aDCDA CK1
0899251	6"	RK 757a/757aDCDA CK1

Kit consists of: First check module, Check module O-ring, Disc elastomer

2nd Check Kits

0899254	2½" - 4"	RK 757a/757aDCDA CK2
0899255	6"	RK 757a/757aDCDA CK2

Kit consists of: Second check module, Check module O-ring, Disc elastomer

ORDERING NO.	SIZE	MODEL
--------------	------	-------

1st or 2nd Check Rubber Parts Kits

0899258	2½" - 4"	RK 757a/757aDCDA RC4
0899259	6"	RK 757a/757aDCDA RC4

Kit consists of: Check module O-ring, Disc elastomer and E-clip

1st or 2nd Check Cover Kits

0899266	2½" - 4"	RK 757a/757aDCDA C
0899267	6"	RK 757a/757aDCDA C

Kit consists of: Closure sleeve, 2 pieces of sleeve O-ring



Watts USA Website: www.wattsreg.com • Watts Canada Website: www.wattscda.com