

Series 008QT

Spill-Resistant Pressure Vacuum Breaker

Sizes: 3/8", 1/2", 3/4" and 1"

Function: To protect the potable water supply against backflow from a non-potable source due to negative supply pressure

Protection: Against back-siphonage backflow

Installation Requirements:

1. Install a minimum of 1" above flood level of fixture if factory deck mounted or not less than 6" if general plumbing field application.
2. Install bonnet side up and allow for accessibility for testing/service. Do not install in concealed locations or areas where water leakage due to normal wear of the internal parts can cause damage.
3. Do not undersize supply or oversize the valve in relation to demand.
4. Do not install where back-pressure can occur.
5. Protect from freezing.

Note: Use "L" suffix for left-hand outlet.

6. The installation of a strainer ahead of the backflow preventer is recommended to prevent fouling of the check assembly and resultant spillage from the valve during repressurizing.

Recommended Service:

Test periodically as required by local jurisdictional authorities.
 Replace internal components every five years.

Pressure - Temperature

Working Temp:	33°F - 180°F
Max. Pressure:	150 psi
Min. Pressure:	8 psi

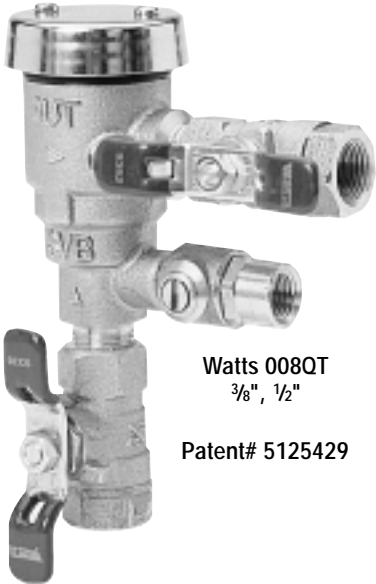

Watts 008QT
3/8", 1/2"

Patent# 5125429



Watts 008QTS
3/4", 1"

Installations

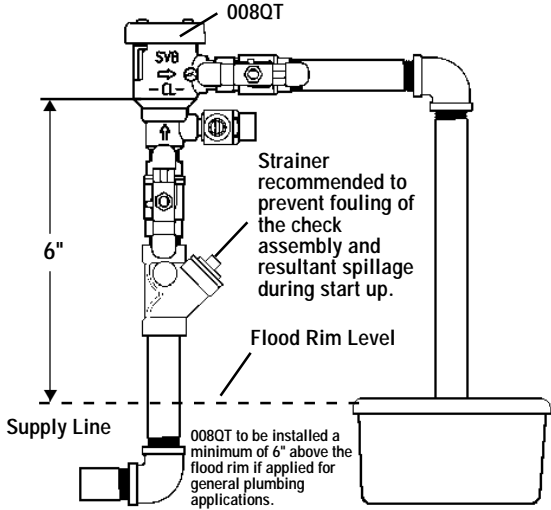
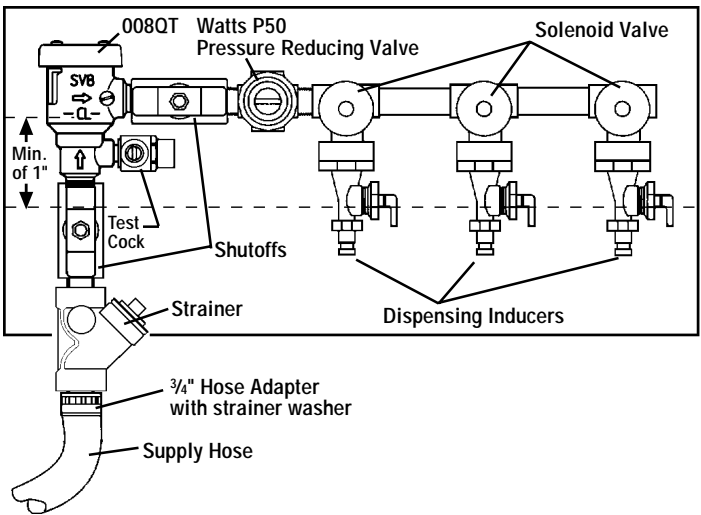

USA: 815 Chestnut St., No. Andover, MA 01845-6098; www.wattsreg.com
 Canada: 5435 North Service Rd., Burlington, ONT. L7L 5H7; www.wattscda.com



LIMITED WARRANTY: Watts Regulator Company warrants each product against defects in material and workmanship for a period of one year from the date of original shipment. In the event of such defects within the warranty period, the Company will, at its option, replace or recondition the product without charge. This shall constitute the exclusive remedy for breach of warranty, and the Company shall not be responsible for any incidental or consequential damages, including without limitation, damages or other costs resulting from labor charges, delays, vandalism, negligence, fouling caused by foreign material, damage from adverse water conditions, chemicals, or any other circumstances over which the Company has no control. This warranty shall be invalidated by any abuse, misuse, misapplication or improper installation of the product. **THE COMPANY MAKES NO OTHER WARRANTIES EXPRESS OR IMPLIED EXCEPT AS PROVIDED IN THIS LIMITED WARRANTY.**

Test Procedure for Spill-Resistant Vacuum Breaker

Note: For both of the following tests the test kit must be held at the same level as assembly being tested.
A. Before starting test, all needle valves and bleed valves on test kit must be closed. **B.** Flush test cocks before test.

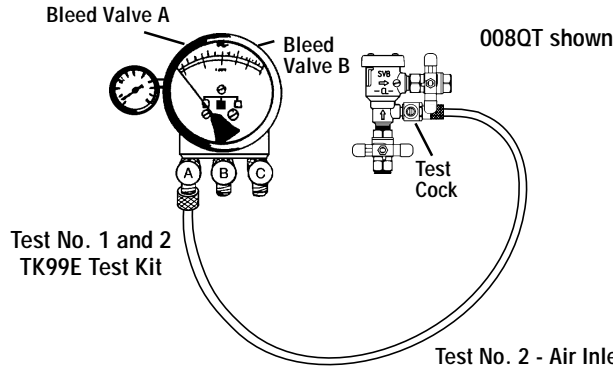

Test No. 1 Differential Test

Requirement: Differential pressure across check must be 1.0 psi or above

- Step 1** Remove two screws on top of hood then remove hood.
- Step 2** Install hose between test cock and connection "A" high side (red) of test kit.
- Step 3** Open test cock then open bleed valve "A" on top of test kit. Bleed air from hose then close bleed valve "A" on top of test kit.
- Step 4** Open needle valve "A" on high side (red) of test kit.
- Step 5** Close shutoff valve No. 2 then shut off valve No. 1 on test assembly.
- Step 6** Slowly unscrew bleed screw on spill proof vacuum breaker body to relieve pressure down stream of check (about 3 turns).
- Step 7** When dripping from bleed screw stops and psi needle on gauge stabilizes, record the differential pressure.

Test No. 2 - Air Inlet - Vent Opening

Requirement: Air inlet must start to open when supply pressure is 1.0 psi or above. Air inlet must be fully open when supply pressure is atmospheric.

- Step 8** Slowly open needle valve "C" bypass (yellow) until psi gauge reads 1.0 psi then close needle valve "C" bypass (yellow) holding pressure at 1.0 psi.
- Step 9** Visually inspect that the vent on top is slightly open, about 1/32" to pass test.
- Step 10** Open needle valve "C" bypass (yellow) fully until dripping from connection "C" stops.
- Step 11** Visually inspect that the vent is fully open to pass test.
- Step 12** Replace hood and two screws on top of assembly.
- Step 13** Restore valve to original working condition.

Note: After test, all valves on test kit must be fully open and hose removed to prevent damage to test kit.

Service and Replacement Parts

Internal parts can be removed, repaired or inspected without removing the valve from the piping.

Disassembly:

1. Shut off supply pressure and drain valve.
2. Remove the two hood screws, remove hood.
3. Unscrew the bonnet by turning counterclockwise.
4. Lift retainer and check assembly from valve body. To assist with removal a small flow can be applied by "cracking" the inlet valve slightly. Alternately the test cock may be opened to break any suction caused by lifting internal assembly. Be sure to close test cock before pressurizing valve.

Reassembly:

Install new retainer module assembly into valve body by aligning "U" shaped cutout in retainer with the valve outlet. The top of retainer must drop just below threads in the valve body. Reassemble remaining parts in reverse order.

Caution:

Spillage may occur if diaphragm is ruptured. Care must be taken not to damage parts during assembly.

008QT Repair Kits

Check Kit

EDP No.	Kit No.	Size
0887972	RK 008 T	3/8" - 1/2"
0887974	RK 008 T	3/4" - 1"

Kits consist of: Check assembly, O-ring, Spring, Vent O-ring, Bleed screw O-ring and Retainer.

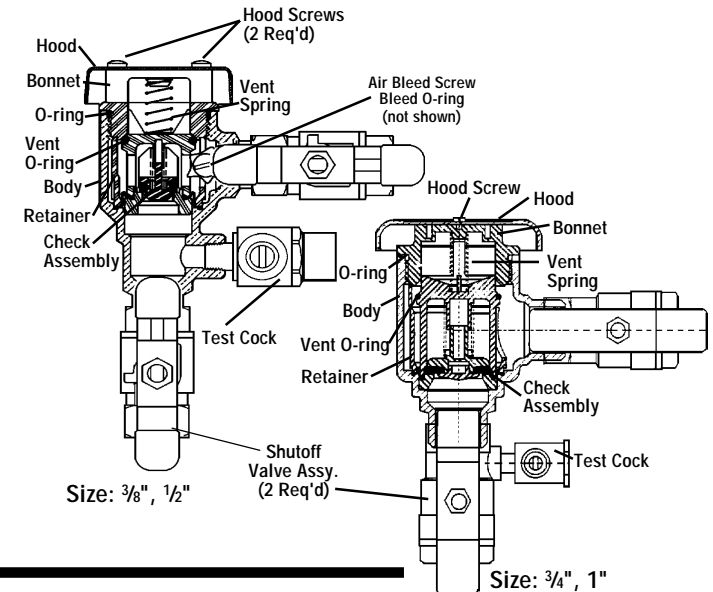

Bonnet Kit

EDP No.	Kit No.	Size
0888012	RK 008 B	3/8" - 1/2"
0887973	RK 008 B	3/4" - 1"

Kits consist of : Bonnet, Bonnet O-ring and Vent spring.

CALIFORNIA PROPOSITION 65 WARNING

WARNING: This product contains chemicals known to the State of California to cause cancer and birth defects or other reproductive harm. (Installer: California law requires that this warning be given to the consumer.)